

Speed Nuts

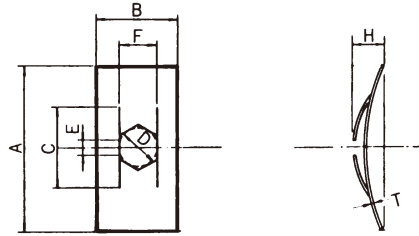

Unit: mm

Dimensions Codes	Nominals	D		A		B		C	E	F	T		H	
		Basic Size	Tolerance	Basic Size	Tolerance	Basic Size	Tolerance				Basic Size	Tolerance	Basic Size	Tolerance
32018	1.8	1.5	+0.08 -0.05	12	±0.4	6	±0.2	7	0.8	3	0.4	±0.03	2.5	±0.45
32020	2	1.8		12		6		7	0.8	3	0.4		2.5	
32025	2.5	2.3		14		7		8	0.8	3.5	0.4		2.7	±0.5
32030	3	2.8		14		7		8	0.8	3.5	0.4		2.7	
32035	3.5	3.3		15		8.5		10	0.8	4.5	0.4		2.8	
32040	4	3.8		16		9		9.6	1	4.5	0.5		±0.035	

Product code	132	Material code	02...SUS304-CSP		Part Number Structure (Standardized Product Code)									
					Product		Surface							
Surface code	01...Burnished	Hardness	HRC 37 - 46		①	③	②	②	①	○	○	○	○	○
						Material			Dimensions code					

Push Nuts

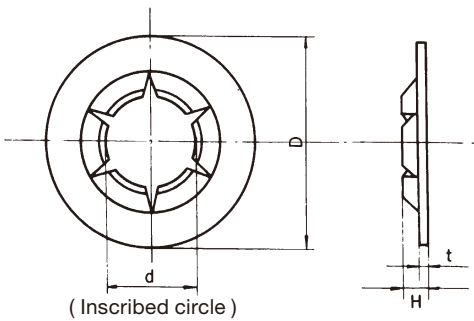

Unit: mm

Dimensions Codes	Nominals	d		D	H	t		Applicable Shafts (Ref.)		Thrust Loading N
		Basic Size	Tolerance			Basic Size	Tolerance	Basic Size	Tolerance	
33012	1.2	1.1	0 -0.1	4.5	0.6	0.25	±0.03	1.2	+0.05 0	196
33015	1.5	1.4		5.2	0.65	0.25		1.5		196
33020	2	1.9		6	0.7	0.25		2		245
33024	2.4	2.3	0 -0.15	7	0.8	0.25	±0.04	2.4	±0.05 0	343
33030	3	2.9		10	1.3	0.3		3		785
33040	4	3.9		12	1.4	0.3		4		981
33050	5	4.9		14	1.55	0.4		5		1,471
33060	6	5.9		16	1.75	0.4		6		1,667
33080	8	7.9		17.5	1.8	0.5		8		2,157
33100	10	9.9	21	2.2	0.7	±0.05	10	3,138		
33120	12	11.9	27	2.8	0.9	±0.06	12	4,903		

- Remarks: 1. Thrust loading is measured with SUS304-CSP.
2. Thrust loading measured using steel shaft with hardness HV300 or less.

Product code	133	Material code	02...SUS304-CSP 70...Spring Steel		Part Number Structure (Standardized Product Code)								
					Product		Surface						
Surface code	01...Burnished (SUS304-CSP)	Hardness	HRC37 - 46 (SUS304-CSP)		①	③	③	○	○	○	○	○	○
	05...Phosphate Coating (Spring Steel)			HRC42 - 50 (Spring Steel)		Material			Dimensions code				