

Split Rings

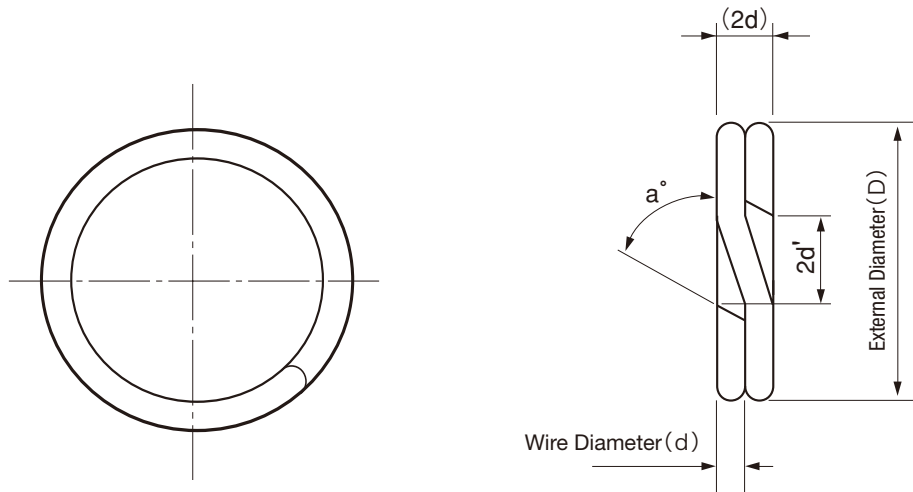

Unit: mm

Dimensions Codes	Nominals No.	Wire Diameter (d)		External Diameter (D)		a Ref.	2d Ref.	2d' Ref.
		Basic Dimension	Tolerance	Basic Dimension	Tolerance			
28100	00	0.40	±0.01	3.2	±0.2	45°	0.8	0.8
28000	0	0.45		3.6			0.9	0.9
28001	1	0.55		4.4			1.1	1.1
28002	2	0.65		5.0			1.3	1.3
28003	3	0.75		6.0			1.5	1.5
28004	4	0.90	±0.015	7.2	±0.3	75°	1.8	1.8
28005	5	1.10		8.1			2.2	2.2
28006	6	1.20		9.0			2.4	2.4

Remarks: 1. Coils shall be closed.
2. Black colored Split Rings are also available (Surface code is 40 - Oxidation Coloring SS Bronze finish).

Product code	128	Material code	48...SUS304-WPB		Part Number Structure (Standardized Product Code)										
					Product		Surface		Material		Dimensions code				
Surface code	01...Burnished	Hardness			①	②	⑧	④	⑧	①	○	○	○	○	○
	40...Black Coloring				Material		Dimensions code								